

Operating Instructions

Universal™ Burnishing Tools

Set-up and operating instructions for UBT-T Tools

Note: UBT™ single-roll burnishing tools do not have the advantage of an overlapping effect as with multi-roll tools, and for this reason slower feed rates and/or multiple passes over the part may be required in order to produce the desired finish.

UBT1 tool set-up

Loosen the load *adjusting screw*. Retighten the *adjusting screw* until it comes into contact with the spring. Continue to tighten screw 1/2 turn past snug. This is a recommended starting point for mild steel.

Adjustments can be made to the burnishing force to achieve optimum finish. Tighten the *adjusting screw* clockwise one turn to increase the burnishing force, or counterclockwise to reduce the force.

Roll orientation is adjustable in 22°-30' increments. Loosen *mounting screws* two turns. Lift *housing* from *shank*. Rotate to desired position, making sure castellations are engaged. Tighten *mounting screws*.

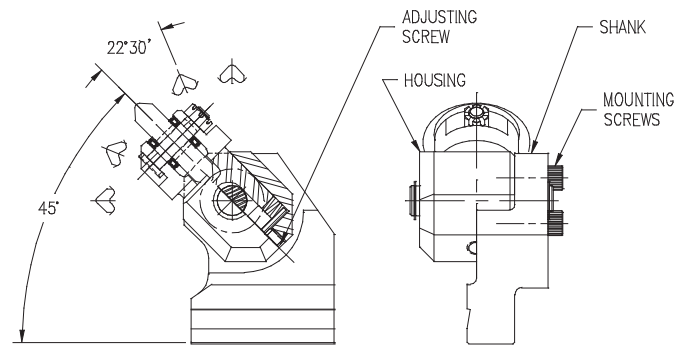

Left hand style shown

UBT2 tool set-up

Loosen the load *adjusting screw*. Retighten the *adjusting screw* until it comes into contact with the spring. Continue to tighten screw four turns past snug. This is a recommended starting point for mild steel.

Adjustments can be made to the burnishing force to achieve optimum finish. Tighten the *adjusting screw* clockwise to increase the burnishing force, six turns total, or counterclockwise to reduce the force.

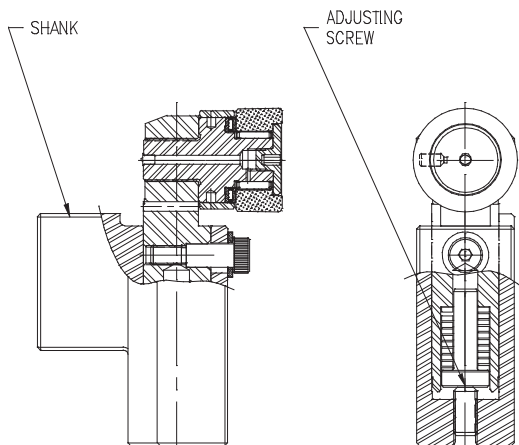

Left hand style shown

UBT3 tool set-up

Loosen the load *adjusting screw*. Retighten the *adjusting screw* until it comes into contact with the spring. Continue to tighten screw two turns past snug. This is a recommended starting point for mild steel.

Adjustments can be made to the burnishing force to achieve optimum finish. Tighten the load *adjusting screw* clockwise to increase the burnishing force, six turns total, or counterclockwise to reduce the force.

To index to a new roll station, pull off *cover*. Loosen *locking screws* and slide *cage* forward approximately 0.157 (4.0mm) until it disengages from *pin*. Rotate *cage* approximately 60°, until *pin* aligns with slot in *cage*, and push back. Tighten locking screws and replace *cover* in position shown.

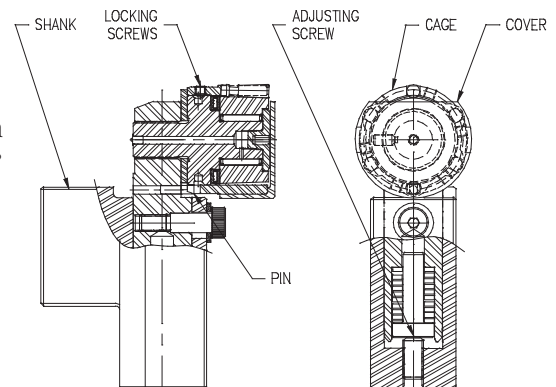

Left hand style shown

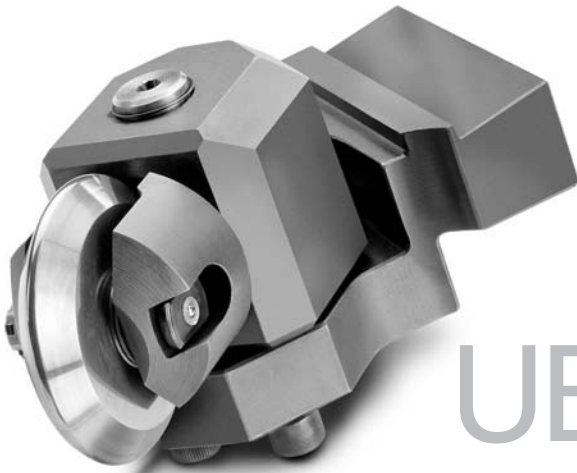

UBFT TOOLS

Set-up and operating instructions for UBFT-T tools

UBFT tool operation

Mount any UBFT tool in the desired turning station. Use a UBFT tool that corresponds with the respective turning tool. Bring the tool into contact with the part to be burnished; contact has occurred when you see the mandrel rotating.

Feed the tool another 0.003-0.005 inch (0.08-0.13mm) into the part to provide interference between the roll

and part so that the roll will float in its spring travel. Interference should not be used to increase burnishing force; burnishing force should only be adjusted with the load adjusting screws. This ensures the tool can be fed on/off the part and across interruptions without damage to the tool or workpiece.

For optimum results and long tool

life, coolant is required. Any soluble, synthetic, or straight oil can be used. Whenever possible, and for best results, the tool should be fed towards the spindle when burnishing diameters and towards the centerline when burnishing faces. (Note: UBFT-T2 and UBFT-T3 tools cannot be used to burnish faces.)

ROLLS FOR UBFT TOOLS

ITEM NO.	TOOL TYPE	ROLL TYPE & RADIUS
UBT-006	UBT-T1	HARDENED STEEL, .093 IN. (2.36MM)
UBT-007	UBT-T1	HARDENED STEEL, .030 IN. (0.76MM)
UBT-010	UBT-T1	CARBIDE, .093 IN. (2.36MM)
UBT-015	UBT-T2	HARDENED STEEL, .060 IN. (1.52MM)
UBT-016	UBT-T2	CARBIDE, .060 IN. (1.52MM)
6100-708-00312	UBT-T3	HARDENED STEEL, .030 IN. (0.76MM)

Speed and feed recommendations

SPEED	
IPR	MM/REV.
0.001/0.006	0.02/0.15

FEED	
SFM	M/MIN.
750	230

Lubrication

All UBFT and UBTB tools should be periodically greased (approximately every 24 hours of operation). We recommend the use of high-quality Lithium complex grease.

Refer to *Burnishing Tools & Machines catalog no. 500* for information on part preparation and operating parameters for burnishing.



www.cogsdill.com

COGSDILL TOOL
products, inc.

Cogsdill Tool Products, Inc. PH. 803-438-4000 FAX 803-438-5263 cogsdill@cogsdill.com	Cogsdill-Nuneaton Ltd. PH. +44(0)2476 383792 FAX +44(0)2476 344433 sales@cogsdill.co.uk
---	--